

SERVICE INSTRUCTION WORK SHEET

CARTER CARBURETOR

1 BARREL—MODEL YH

1. Carefully read the text in the following pages to become familiar with the contents of this worksheet before performing carburetor overhaul.
2. The exploded view is typical of the model carburetor this kit will service. The view may differ slightly from the actual carburetor being overhauled.

3. Use the exploded view as a guide. The numerical sequence of the parts list generally be followed to disassemble the carburetor far enough to permit cleaning and inspection.
4. Parts list shown DOES NOT reflect the contents of the kit.
5. Kit may contain extra parts intended for other carburetors within this group. Substitute identical replacement parts for original worn parts found in carburetor.

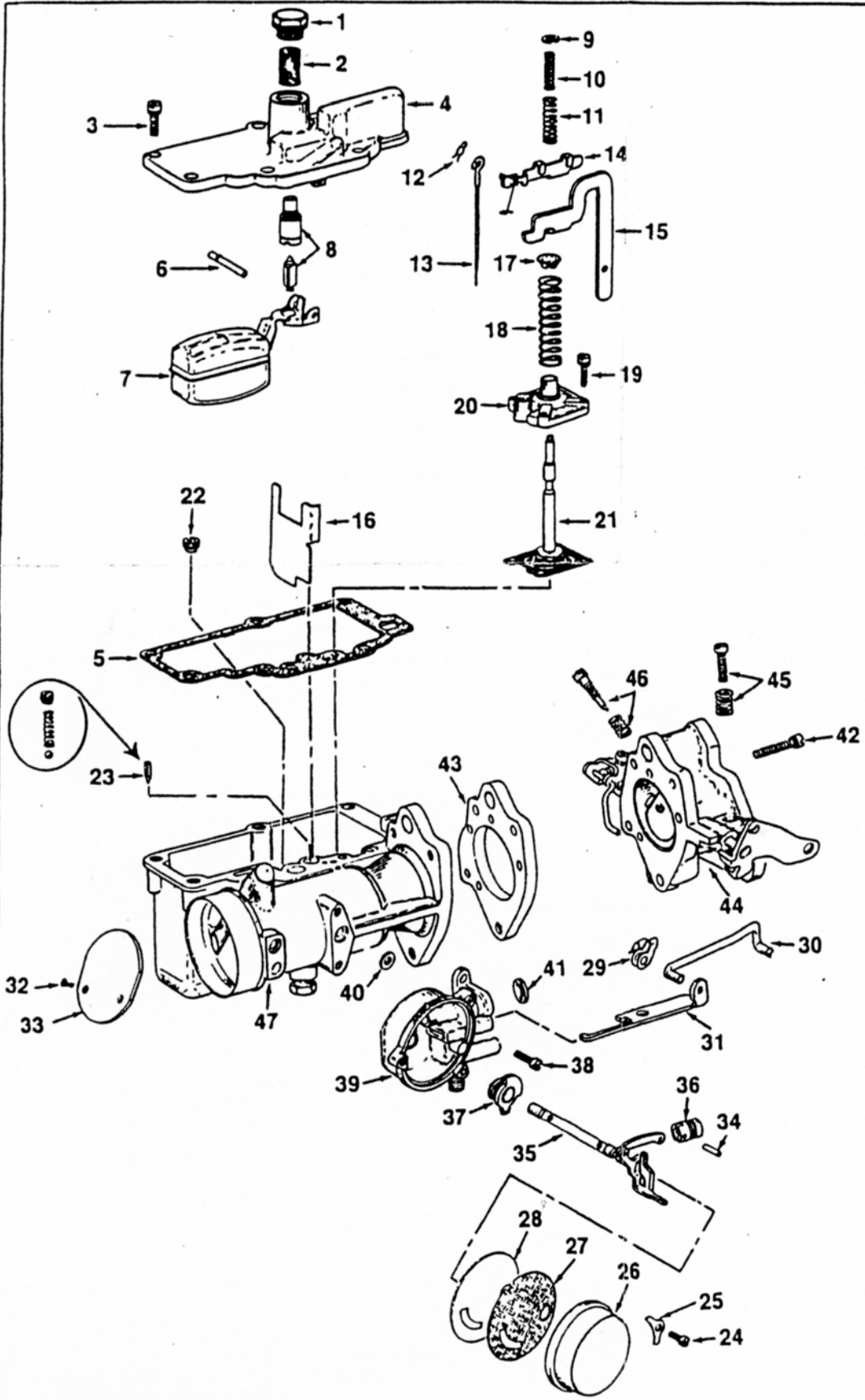

CLEANING

Cleaning must be done with carburetor disassembled. Use spray cleaner and a stiff bristle brush to remove dirt and carbon deposits. Do not use abrasives and wires to clean parts and passageways. Wash off in suitable solvent, and clear all passageways with compressed air.

CAUTION: When cleaning with solvent do not soak or spray parts containing rubber, leather, plastic and electrical components.

SPECIAL NOTES:

1. Cover opening on intake manifold after carburetor is removed.
2. Note position of baffle plate (16) before removal, to assure correct installation.
3. Some carburetor models have parts shown in insert instead of pump check needle (23).
4. Remove parts 34, 35, 36, 37, 38, 39, 40, 41 only if necessary, by first filing ends of screws (32).
5. Assemble in reverse order of disassembly.
6. When installing idle adjusting screw (46), turn in until lightly seated, then back out approximately 1 turn for initial setting.
7. Make sure diaphragm assy. (21) is aligned in housing before installing screws and tightening.
8. Install float pin (6) with shoulder of pin away from bore of carburetor.
9. Fast idle unloader adjustments must be made before installing parts 28, 27, 26, 25 & 24. On some models, fast idle adjustment is omitted.

PARTS LIST

1. Plug, fuel filter
2. Filter, fuel
3. Screw, bowl cover (6)
4. Cover assembly, bowl
5. Gasket, bowl cover
6. Pin, float hinge
7. Float assembly
8. Needle & seat assembly
9. Retainer, upper spring
10. Spring, upper pump (inner)
11. Spring, upper pump (outer)
12. Cotter pin
13. Rod, metering
14. Arm assy., metering rod
15. Arm, pump lifter
16. Baffle plate
17. Retainer, diaphragm spring
18. Spring, pump diaphragm
19. Screw, diaphragm housing (4)
20. Housing, pump diaphragm
21. Pump diaphragm assembly
22. Metering jet
23. Needle, pump check
24. Screw, coil housing (3)
25. Retainer, coil housing (3)
26. Thermostatic coil housing assy.
27. Gasket, coil housing
28. Baffle plate
29. Retainer, choke rod
30. Rod, choke connector
31. Link, fast idle
32. Screw, choke valve (2)
33. Choke valve
34. Pin, choke piston
35. Choke shaft & lever assy.
36. Piston, choke
37. Cam assy., fast idle
38. Screw, piston housing (3)
39. Housing, piston & plug assy.
40. Washer, piston housing
41. Welsh plug
42. Screw, throttle body (3)
43. Gasket, throttle body
44. Throttle body assembly
45. Screw & spring, throttle lever adjusting
46. Screw & spring, idle adjusting
47. Main body assembly

ADJUSTMENT DATA

**FIG. 1
FLOAT ADJUSTMENT**

1. Remove gasket and invert bowl cover. (Float resting on needle).
 2. Measure distance between top of float and bowl cover surface.
 3. To adjust, bend float lever.
- CAUTION:** No pressure should be exerted on fuel inlet needle as damage to tip and/or false setting will result.

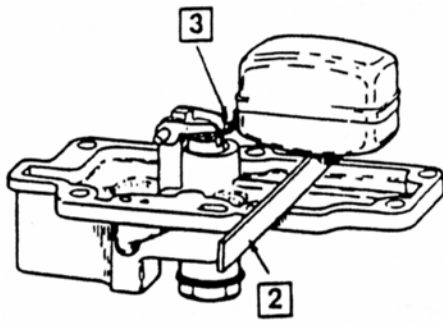

**FIG. 2
FLOAT DROP ADJUSTMENT**

1. Remove gasket and hold bowl cover upright.
2. Measure distance from bowl cover surface to bottom of float.
3. To adjust, bend tang.

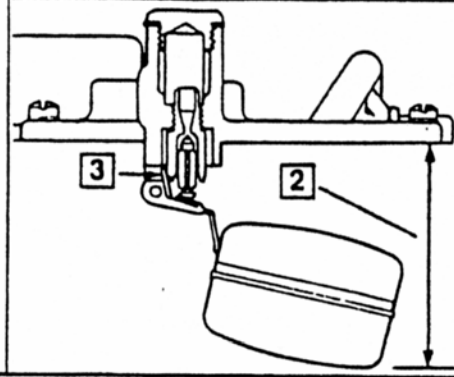

**FIG. 3
METERING ROD ADJUSTMENT**

NOTE: Metering rod in place.

1. Close throttle valve by backing out idle speed screw.
2. Press down on diaphragm (A) until metering rod arm (B) contacts lifter link (C) at diaphragm stem.
3. At this position, top of metering rod (D) should be flush with casting (E).
4. To adjust, bend metering rod arm at (F).

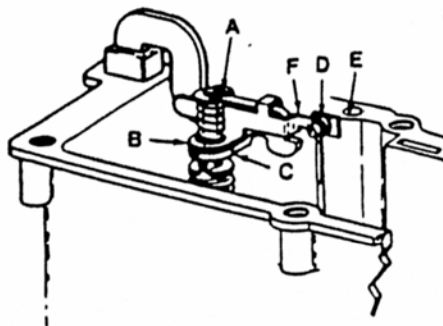

**FIG. 4
UNLOADER ADJUSTMENT**

1. Hold throttle valve wide open and close choke valve without forcing.
2. Measure distance between lower edge of choke valve and wall of air horn using a gauge or drill bit.
3. To adjust, bend unloader arm as shown.

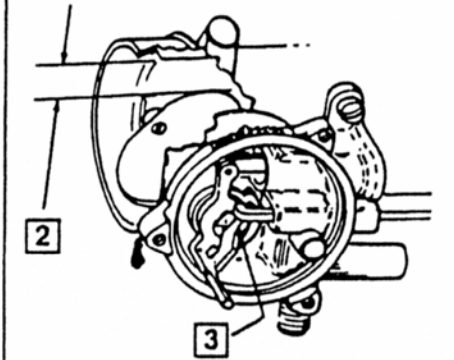

**FIG. 5
FAST IDLE ADJUSTMENT**

1. Partially open throttle valve, close choke valve, then close throttle valve to assure fast idle cam is in fast idle position.
2. Hold choke valve tightly closed and measure distance between throttle valve and bore using a gauge or drill bit.
3. To adjust, bend choke rod at elbow.

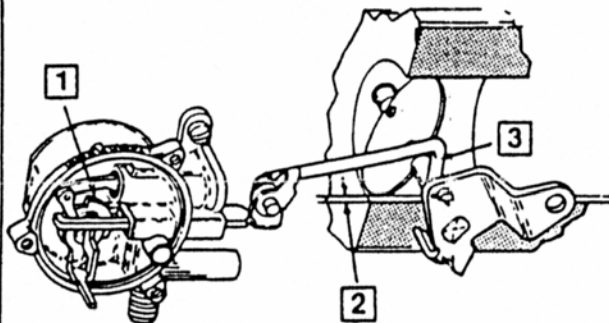

**FIG. 6 (Refer to Exploded View)
IDLE ADJUSTMENT**

1. Turn throttle adjusting screw (45) in to open throttle valve slightly.
2. Start engine and allow to warm up.
3. Adjust screw to obtain specified RPM.
4. Turn mixture screw (46) in or out to obtain smooth idle.

SPECIFICATION CHART

Year	Application	Float Level	Float Drop	Fast Idle	Unloader	Auto. Choke	Engine RPM ¹
AMERICAN MOTORS							
1955-52	M/T	5/16	2-3/8	.033	1/2	1NR	550
CHEVROLET							
1966-63	145, 164 Eng.	5/8	2-3/8	.033	7/16	1NL	800
1962	145 Eng.	5/8	2-3/8	.033	7/16	1NR	800
CHRYSLER MARINE							
	M(80) 318, (M81) 361 Eng.	5/8	2-3/8	—	5/8	Index	500
CRUSADER MARINE							
	(Mark IV)-(Mark V) 283 Eng.	5/8	2-3/8	—	5/8	Index	500 ²
DEARBORN MARINE							
	125, 144, 145, 165, 185, 215 Eng.	9/16	2-3/8	.015 ³	5/8	Index	700
GRAY MARINE							
	250, 327 Eng.	11/16	2-9/16	—	5/8	Index	500

FOOTNOTES:

- ¹ Transmission in neutral.
- ² Carb. No. 2618 set 700.
- ³ Early Models only.

ABBREVIATIONS:

- M/T - Manual Transmission
- NL - Notch Lean
- NR - Notch Rich